

# 使用说明书 User Manual

使用产品前请仔细阅读本使用说明书，并保留备用。  
Before using the product, please read the User  
Manual carefully and keep it for future reference.

# TOTO

# TOTO

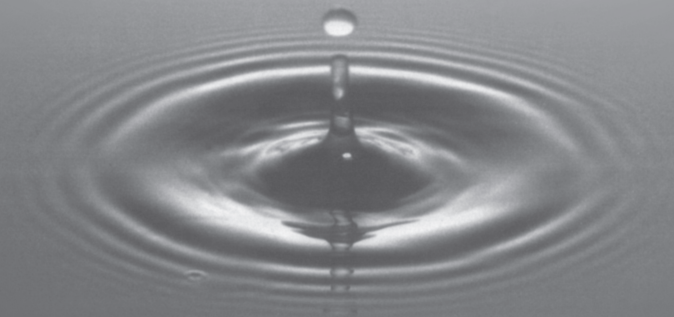

**OG540Y**  
**2021.06**

# 目录

## 目 录

|             |     |
|-------------|-----|
| 目录          | 1   |
| 明细单         | 2   |
| 使用条件与使用上的注意 | 3   |
| 使用上的注意与保养   | 4   |
| 产品示意图       | 5   |
| 拆卸与检查       | 6-7 |
| 产品保修卡       | 8   |
| 合格证         | 9   |

# 明细单

## 明 细 单

|       |    |
|-------|----|
| 水嘴主体部 | 1套 |
| 排水金具  | 1套 |
| 施工说明书 | 1本 |
| 使用说明书 | 1本 |

使用此明细单的产品包括:

- TRG07301\* 铜合金台式单柄双控净身器水嘴 (含排水配件)
- TRG08301\* 铜合金台式单柄双控净身器水嘴 (含排水配件)
- TRG09301\* 铜合金台式单柄双控净身器水嘴 (含排水配件)
- TRG10301\* 铜合金台式单柄双控净身器水嘴 (含排水配件)
- TRG11301\* 铜合金台式单柄双控净身器水嘴 (含排水配件)

# 使用条件与使用上的注意

## 使用条件

1. 供冷水\*热水压强：  
最低压强……0.05MPa（流动压）  
最高压强……1.0MPa（静压）  
推荐使用压强……0.1~0.5MPa（流动压）  
检测压强……1.6MPa（静压）
2. 供水温度在4℃~90℃，建议使用热水温度60℃，供热水请勿使用蒸汽。
3. 使用环境温度0℃以上。如果不高于0℃，水嘴会出现变形、冻裂现象。
4. 长时间不使用时，可能导致水嘴内部及外部锈蚀不能使用等现象。
5. 如果您需要废弃本产品，请勿将其作为一般生活垃圾处理，请依照法规经由独立的回收体系进行合适的处理、恢复和回收。
6. 本说明书中的产品具有清洗功能。

## 使用上的注意

- ⚠ 警告 表示如果无视此标志而误操作时，有可能造成人员重伤或死亡。
- ⚠ 注意 表示如果无视此标志而误操作时，有可能造成人身伤害或财产损失。

### 警告

1. 幼儿禁止使用或幼儿需要由成年人监护使用、老人和残障人士等特殊群体应在有行动能力人员陪同下使用。
2. 水嘴的供热水一侧处于高温状态，请勿使皮肤直接接触五金配件表面，否则可能会烫伤。
3. 请勿配反冷\*热水配管，否则可能会烫伤。
4. 供热水请勿使用蒸汽，否则可能会烫伤。
5. 如果客户不使用我们水嘴自带的进水口过滤网，会出现阀芯因异物进入而导致漏水或破损的风险。

### 注意

1. 由于陶瓷阀芯是较精密的部件，请勿擅自分解，否则可能会造成漏水等不良。

# 使用上的注意与保养

## 注意

2. 请勿撞击本产品，否则可能会造成故障、漏水。
3. 必须使用中性洗涤剂清洗，中性以外的洗涤剂会破坏镀层或使表面变色。
4. 不得使用酸性洗涤剂和去污粉、抛光粉等含粗颗粒的洗涤剂和尼龙刷，否则可能会破坏镀层等。
5. 可使用软布擦拭，间或用机油或车用蜡浸布擦拭，但请勿接触树脂部件，否则可能失去光泽和产生锈蚀。
6. 建议不要长时间不使用，否则可能会导致水嘴内部以及外部锈蚀不能使用等现象。
7. 随着产品式样的不断更新，实物存在与图示不符的情况，但基本安装、使用原理相同。
8. 在可能结冰的场所使用时，要切实做好防冻措施。  
因结冰，零件破损，有可能导致漏水，造成财产损失。因结冰而造成的破损即使在保修期内也是有偿修理。请不要让产品的环境温度低于0℃。

## 防冻措施

- 在可能结冰的场所使用时，要切实做好防冻措施。
1. 产品结冰的话零件损坏，成为漏水的原因。
  2. 因结冰造成的零件破损即使在保修期也是有偿修理。
  3. 施工完了后或长时间不使用时，要有预防突然降温的准备，要对产品进行结冰预防。
  4. 因为有结冰的危险，请不要让产品周围的温度在0℃以下。

## 保养

- 为长期保持产品的美观，请用户按以下方法维护保养。
1. 经常用软布擦拭，间或用软布蘸水擦拭。
  2. 当有污垢且较明显时，请用中性洗涤剂擦拭后充分进行水洗。

# 产品示意图

以TRG07301\*为例

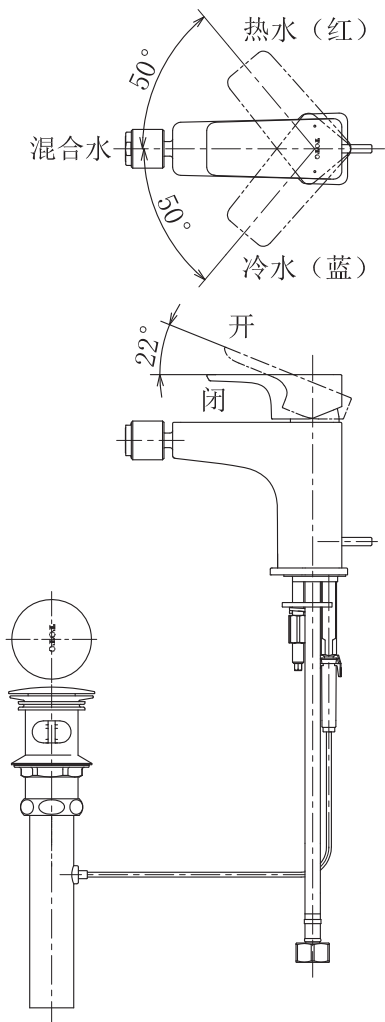

# 拆卸与检查

| 现象       | 检查项目                  |
|----------|-----------------------|
| 水流量小     | 6、11、14               |
| 手柄晃动     | 1、2                   |
| 漏水       | 2、3、7、8、9、10、11、13、15 |
| 本体晃动     | 12                    |
| 提拉捏手操作困难 | 4、5                   |

安装后万一出现故障，请按以下要领拆卸。  
(此图内未拆分的零部件，需要拆卸的情况下，  
请联络售后服务人员进行拆卸)

例：TRG07301\*

共通品番：  
TRG08301\*、  
TRG09301\*、  
TRG10301\*

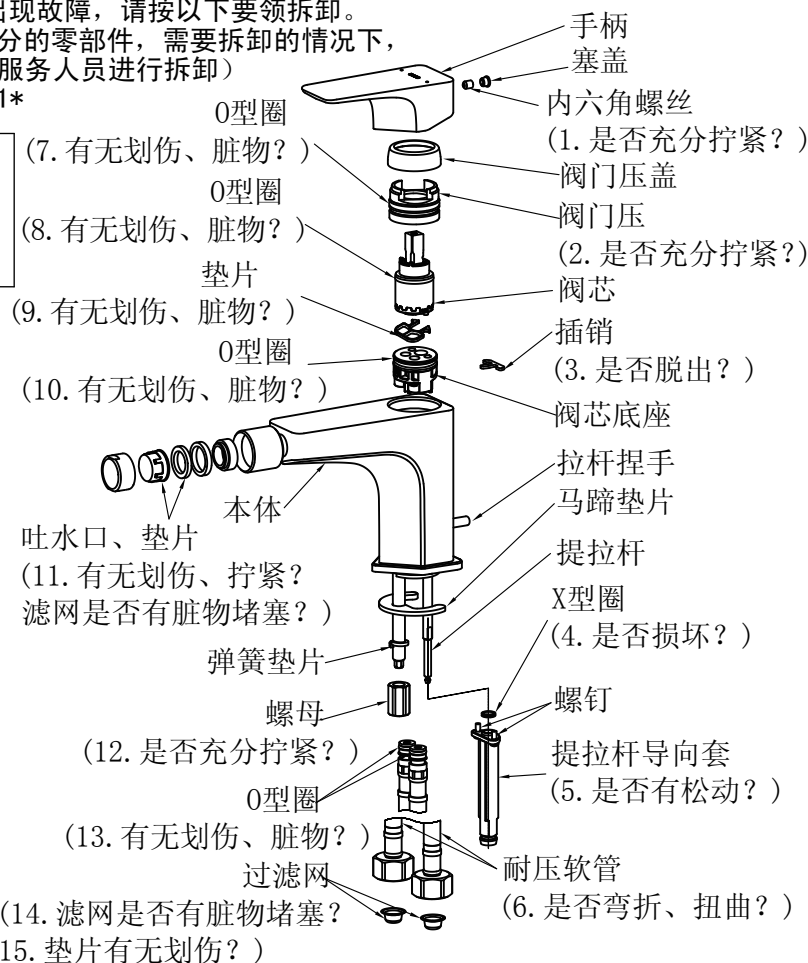

※不同示例产品的拆卸与原理基本相同。

# 拆卸与检查

| 现象       | 检查项目                  |
|----------|-----------------------|
| 水流量小     | 6、11、14               |
| 手柄晃动     | 1、2                   |
| 漏水       | 2、3、7、8、9、10、11、13、15 |
| 本体晃动     | 12                    |
| 提拉捏手操作困难 | 4、5                   |

安装后万一出现故障，请按以下要领拆卸。  
 (此图内未拆分的零部件，需要拆卸的情况下，  
 请联络售后服务人员进行拆卸)  
 例：TRG11301\*

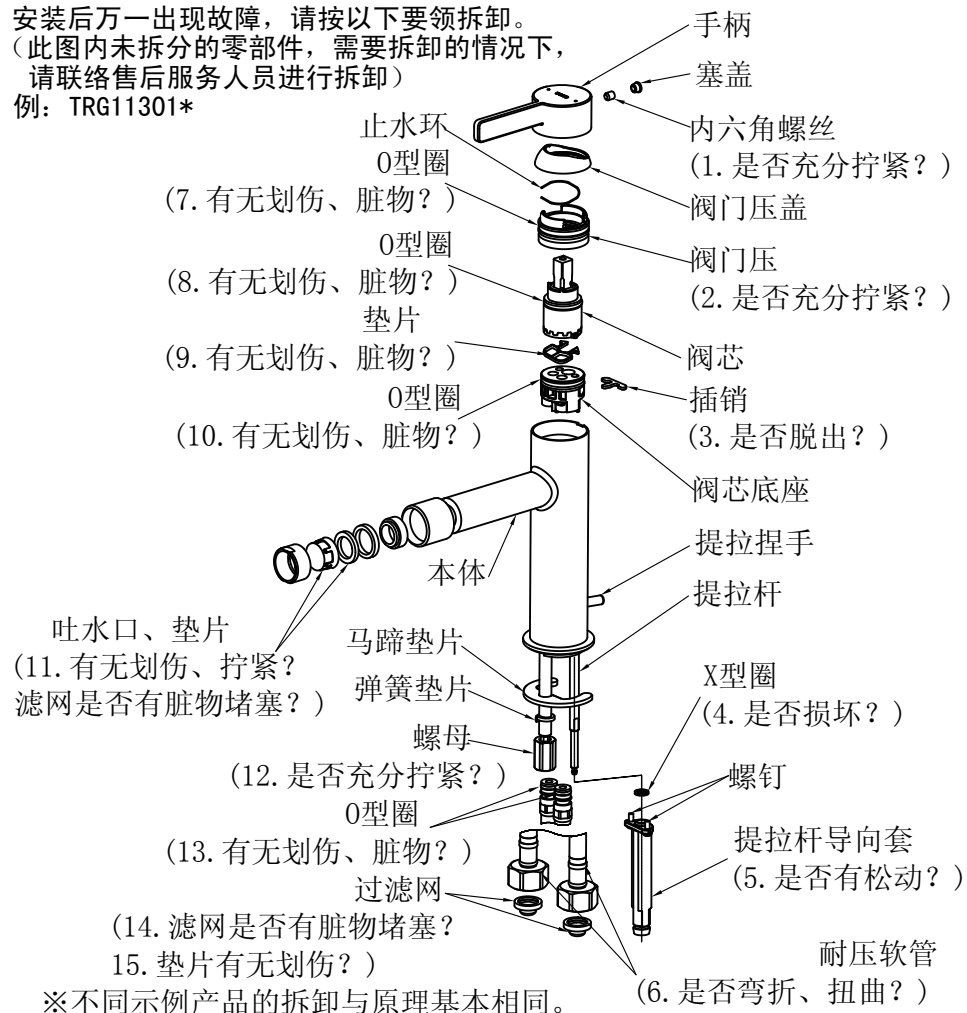

※不同示例产品的拆卸与原理基本相同。

# 产品保修卡

|       |                               |
|-------|-------------------------------|
| 用户    |                               |
| 销售安装店 |                               |
| 购买日   |                               |
| 保修期   | 自购买日起本体及阀芯保修有效期5年，其余部件保修期为1年。 |

- \*若上栏内容未记全，该保修卡将视为无效。因此请用户购买时对记入内容进行确认。
- \*本产品保修卡中的保修项目仅限于保修卡中所约束的免费维修项目进行维修。
- \*在保修期间，若产品发生故障（漏水、渗漏），请拨打全国售后服务电话报修。

## 维修规定

1. 保修期间，在用户正确按安装说明书、不干贴等指示，使用本公司产品的情况下，本公司将对有故障产品进行免费维修。
2. 在保修期内发生损坏需要得到免费维修时，请拨打全国售后服务电话报修。
3. 在保修期内，下面所列场合的维修为有偿维修。
  - ① 使用不当或私自进行的不当修理及改造所造成的故障及损伤。
  - ② 安装施工时的不注意或过失造成的故障及损伤。
  - ③ 安装后又拆移等原因造成的故障及损伤。
  - ④ 超出使用范围以外的场合下使用本产品所造成的故障及损伤（如家庭用商品作为业务上商品使用）。
  - ⑤ 沙粒或污物等造成的损伤。
  - ⑥ 由于日常的维护保养不当造成的肮脏、电镀部分生锈等不良。
  - ⑦ 由于火灾、地震、水灾、雷击及其他天灾、公害、气害（液化气）、盐害及异常电压、使用指定外的电源（电压、频率）等原因造成的故障及损伤。
  - ⑧ 本保修卡没有指定的场合。
  - ⑨ 本保修卡中用户姓名、销售店、安装店、购买日期未填写的场合。
  - ⑩ 不能出示购买发票的场合。
  - ⑪ 由结冰引起的故障。
4. 本保修卡仅适用于中国国内。
5. 本保修卡丢失不补，请顾客妥善保管。

# 合格证

本产品经检查判定合格

执行标准：GB18145-2014、GB25501-2019

产品型号：见包装箱上的标签

产品名称：见包装箱上的标签

生产日期：见包装箱上的标签

组装工厂：东陶(大连)有限公司

电 话：(0411) 87624383

厂 址：大连经济技术开发区东北二街17号

东陶(中国)有限公司

全国售后服务电话：800-820-9787(固定电话)

400-820-9787(手机用户)



扫描二维码，  
服务预约，方便快捷

销售商：东陶(中国)有限公司

地 址：北京市朝阳区光华路1号 北京嘉里中心北楼1915室

网 址：www.toto.com.cn

# Table of Contents

## Table of Contents

|   |     |
|---|-----|
| Table of Contents .....                 | 1   |
| Specification.....                      | 2   |
| Conditions and Attentions for Use ..... | 3   |
| Attention and Maintenance for Use.....  | 4   |
| Product Structure Diagram.....          | 5   |
| Disassembly and Inspection .....        | 6-7 |
| Product Warranty Card .....             | 8   |



# Specification

## Specification

|                             |           |
|-----------------------------|-----------|
| Main Body of the Spout..... | 1 set     |
| Drain Assembly.....         | 1 set     |
| Installation Manual.....    | 1 booklet |
| User Manual.....            | 1 booklet |

Products using this specification include:



- TRG07301\* "GE" Bidet Faucet(including drainage fittings)
- TRG08301\* "GC" Bidet Faucet(including drainage fittings)
- TRG09301\* "GM" Bidet Faucet(including drainage fittings)
- TRG10301\* "GB" Bidet Faucet(including drainage fittings)
- TRG11301\* "GF" Bidet Faucet(including drainage fittings)

# Conditions and Attentions for Use

## Use Conditions

1. Pressure for cold water \* hot water supplying  
Minimum pressure..... 0.05MPa (flow pressure)  
Maximum pressure..... 1.0MPa (static pressure)  
Recommended pressure..... 0.1~0.5MPa (flow pressure)  
Detection pressure..... 1.6MPa (static pressure)
2. The water supply temperature is between 4°C and 90°C. It is recommended to use hot water temperature of 60 °C. Do not use steam when supplying hot water.
3. Ambient temperature of the use above 0°C. If it is lower than 0°C, the spout will have some issues such as deformations, cracking, etc..
4. When it is not used for a long time, it may cause the inside and outside of the spout to rust and corrode, leading to malfunction.
5. If you need to dispose of this product, do not dispose of it as general household waste. Please follow the regulations to properly dispose, recover and recycle it through an independent recycling system.
6. The products stated in the Manual have a cleaning function.

## Attention on Installation

-  Warning: Indicates that if you overlook this sign, causing misoperation, it may result in serious injury or death.
-  Attention: Indicates that if you overlook this sign, causing misoperation, it may cause personal injury or property damage.

## Warning

1. Children are prohibited from using it or need to be supervised by adults when using it, and special groups such as the elderly and the disabled should be accompanied by people with physical capacity when using it.
2. As one side of the spout to supply hot water is in a high-temperature state, do not let the skin be directly in contact with the surface of the hardware fitting; otherwise it may cause burn injuries.
3. Do not assemble cold \* hot water tubing incorrectly; otherwise it may cause burn injuries.
4. Do not use steam when supplying hot water; otherwise it may cause burn injuries.
5. If the customer does not use the water inlet filter provided, there will be a risk of leakage or damage of the cartridge due to dirt or debris.

# Attention and Maintenance for Use

## ⚠ Attention

1. Since the ceramic valve spool is a relatively precise component, do not disassemble it without authorization; otherwise it may cause water leakage and other defects.
2. Do not hit this product; otherwise it may cause malfunction or water leakage.
3. It must be cleaned with a neutral detergent as other detergents will damage the coating or discolor the surface.
4. Do not use acidic detergents or detergents containing coarse particles, such as cleaning powder and polishing powder, and nylon brushes, as they may damage the coating, etc.
5. It can be wiped with a soft cloth, or wiped with machine oil or a cloth soaked with paraffin for cars occasionally, but do not let them be in touch with the resin parts; otherwise they may lose luster or generate rust.
6. It is recommended not to use it for a long time; otherwise it may cause the rust and corrosion inside and outside of the spout, resulting in malfunction.
7. As the product model is constantly updated, the actual product may not look the same as it is shown in the diagram, but the basic installation and operation principles are the same.
8. When using in places where icing may occur, anti-freezing measures must be taken. The parts will be damaged due to icing, which may cause water leakage and property loss. Damages caused by icing are repaired for a fee even during the warranty period. Please ensure that the ambient temperature of the product is always above 0°C.

## Anti-freezing measures

When using in places where icing may occur, anti-freezing measures must be taken.

1. The parts will be damaged due to icing, which may cause water leakage.
2. Damaged parts caused by icing are repaired for a fee even during the warranty period.
3. After the construction is completed or when it is not used for a long time, prepare to prevent sudden drop of temperature and prevent the product from icing.
4. Because of the risk of icing, please ensure that the ambient temperature of the product is always above 0°C.

## Maintenance

In order to maintain the decent appearance of the product for a long time, please maintain it according to the following methods.

1. Wipe with a soft cloth often, or wipe with a soft cloth with water occasionally.
2. When there is dirt and it is obvious, please wash it with water thoroughly after wiping it with neutral detergent.

# Product Structure Diagram

Example: TRG07301\*

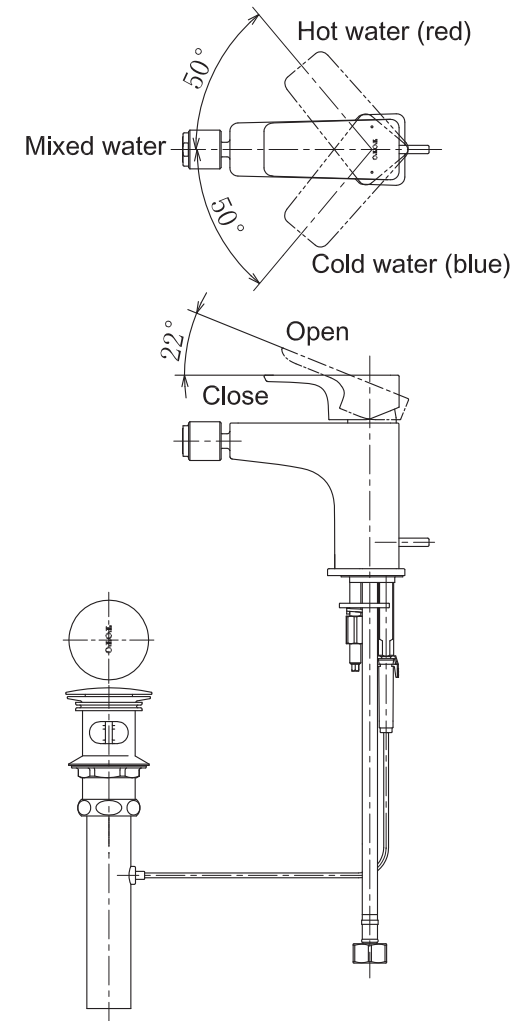



# Disassembly and Inspection

| Issues                                 | Inspection item       |
|--|-----------------------|
| Small water flow                       | 6、11、14               |
| Handle shaking                         | 1、2                   |
| Water leakage                          | 2、3、7、8、9、10、11、13、15 |
| Shaking of the body                    | 12                    |
| Drain lift rod is difficult to operate | 4、5                   |

**In case that there is malfunction after installation, please disassemble it according to the following instructions. (For the parts not disassembled in this figure, if they need to be disassembled, please contact the after-sales service personnel for disassembly)**  
Example: TRG07301\*

General product type numbers:  
TRG08301\*  
TRG09301\*  
TRG10301\*

※ The disassembly principle of different sample products is basically the same.

# Disassembly and Inspection

| Issues                                 | Inspection item       |
|--|-----------------------|
| Small water flow                       | 6、11、14               |
| Handle shaking                         | 1、2                   |
| Water leakage                          | 2、3、7、8、9、10、11、13、15 |
| Shaking of the body                    | 12                    |
| Drain lift rod is difficult to operate | 4、5                   |

**In case that there is malfunction after installation, please disassemble it according to the following instructions. (For the parts not disassembled in this figure, if they need to be disassembled, please contact the after-sales service personnel for disassembly)**  
Example: TRG11301\*

※ The disassembly principle of different sample products is basically the same.

# Product Warranty Card

|                               |   |
|-------------------------------|---|
| User                          |   |
| Sales and installation stores |   |
| Date of purchase              |   |
| Warranty period               | The body and valve spool warranty is valid for 5 years from the date of purchase, and the remaining parts are warranted for 1 year. |

- \*If the contents on the above column are not recorded completely, the warranty card will be considered invalid. Therefore, please confirm the recorded contents at the time of purchasing.
- \*The warranty items in this product warranty card are limited to the free repair items covered by the warranty card for maintenance.
- \*During the warranty period, if the product breaks down (such as water leakage, oozing), please call after sale service to request repairs.

## Repair provisions

1. During the warranty period, under the condition that the users use TOTO products in accordance with the manual and the instructions on the labels, etc., TOTO will repair the malfunctioning products for free.
2. If damage occurs in the warranty period is required to be repaired for free, please call after sale service to request repairs.
3. During the warranty period, the repairs with the following situations are charged.
  - ① Failure and damage caused by improper use, or improper repair or unauthorized modification.
  - ② Failure or damage caused by inattention or negligence during the installation.
  - ③ Failure and damage caused by disassembly after installation.
  - ④ Failures and damages caused by using this product in the sites outside the scope of use (such as residential products used as a commercial product).
  - ⑤ Damage caused by dirt or debris.
  - ⑥ Improper daily maintenance, such as dirt, rust of plating locations.
  - ⑦ Failures and damages caused by fire, earthquake, flood, lightning and other natural disasters, public hazard, gas damage (liquefied gas), salt damage and abnormal voltage, use of the non-specified power source (voltage, frequency) and other reasons.
  - ⑧ The installation locations not specified in this warranty card.
  - ⑨ For the occasions that the user name, sale store, installation store, and the date of purchase are not filled in this warranty card.
  - ⑩ For the occasions that the user is unable to present the purchase invoice.
  - ⑪ Failure caused by icing.
4. This warranty card is only valid in China.
5. This warranty card may not be replaced when it is lost. Please keep it safe.

TOTO Asia Oceania Pte. Ltd.

Telephone: 65-6744-6955

FAX: 65-6841-0819

Address : 10 Eunos Road 8 #12-07 Singapore Post Centre

Singapore 408600

Website: asia.toto.com

TOTO KOREA LTD.

전화번호 : (02)-3141-8236

FAX 번호 : (02)-3141-8240

주소 : 서울시 마포구 상수동 351-16번지 로이코빌딩 3층

홈페이지 : <http://www.totokr.co.kr>